

## Delta T Systems Open Tank Temperature Control Unit

### Technical Specifications

#### DOE 2020 Efficiency Compliant Pumps

This new pump design is compliant with the DOE Energy Conservation Standards. These pumps produce higher outputs measured in flow and pressure compared to the existing design. In addition, the energy consumption is significantly reduced.

#### Heating and Cooling

The standard design allows for a maximum of 36KW heating capacity in one tank in this compact cabinetry. A second, optional tank could be added for a water to water heat exchanger for indirect cooling.

#### Low Maintenance combined with High Reliability

The unit also has the following safety features built in: a bi-metal switch that protects the heater from overheating, circuit protection for the motor, high temperature pump seal and a dry run protection for the heater.

#### Other Design Improvements and Material Considerations

A judicious set of design improvements and material selections makes the new generation of temperature control units less susceptible to traditional maintenance problems, and easier to maintain.

- Industrial strength frame and cabinetry
- Lift off panels on the side for easy access
- IEC compliant components
- Compact heater design which allows for higher capacity on a smaller footprint





# DELTA T SYSTEMS

The True Measure of Temperature Control

## Standard Equipment Features

- 9 to 36 KW Heater
- 180°F (82°C) Fluid Operating Temperature
- Microprocessor-Based PID Controller
- Motor Overload Protection
- Over Temperature Protection
- Low Water Level Switch
- High Pressure Safety Relief Valve Protection
- Liquid-Filled Delivery Pressure Gauge
- Fused Transformer
- Grounded Circuit Control
- Pilot Lights indicating Separate Functions of Use
- Rugged, Heavy Gauge Sheet Metal Cabinet
- 3" Industrial-Grade Casters, swivel and lockable
- Ease of Service Design
- NEMA 1 Electrical Specifications & Wiring in  
Conformance with NEC Electrical Codes
- Solid State Heating Contactor

## Optional Features

- 50 and 60 Hz
- 208, 230 and 460V
- Remote Start/Stop
- Remote Sensor input
- Water to Water Heat Exchanger for indirect cooling
- NEMA Classifications: 3, 4, 4X, 7 and 12 rated enclosures
- Audible or Visual Alarms
- Electrical Main Disconnect
- Automatic Water Make-up
- Anti-Drain Back Kit



# DELTA T SYSTEMS

The True Measure of Temperature Control

Model	Heating Capacity (KW)	Pump Size (HP)	Minimum Circuit Ampacity			Dimensions (in)			Shipping Weight (lbs)
			460V	230V	208V	Height	Width	Depth	
EUW-09C	9	3/4	15.8	31.5	35.5	49.1	32.0	34.9	525
EUW-12C	12	3/4	20.3	40.5	51.1	49.1	32.0	34.9	526
EUW-18C	18	3/4	29.3	58.5	66.8	49.1	32.0	34.9	533
EUW-24C	24	3/4	38.3	76.5	82.5	49.1	32.0	34.9	527
EUW-30C	30	3/4	47.3	94.5	98.0	49.1	32.0	34.9	528
EUW-36C	36	3/4	56.3	112.5		49.1	32.0	34.9	528
EUW-09D	9	1	16.3	32.5	36.875	49.1	32.0	34.9	528
EUW-12D	12	1	20.8	41.5	52.5	49.1	32.0	34.9	529
EUW-18D	18	1	29.8	59.5	68.125	49.1	32.0	34.9	536
EUW-24D	24	1	38.8	77.5	83.875	49.1	32.0	34.9	530
EUW-30D	30	1	47.8	95.5	99.375	49.1	32.0	34.9	531
EUW-36D	36	1	56.8	113.5		49.1	32.0	34.9	531
EUW-09E	9	1-1/2	17.1	34.3	38.625	49.1	32.0	34.9	529
EUW-12E	12	1-1/2	21.6	43.3	54.25	49.1	32.0	34.9	530
EUW-18E	18	1-1/2	30.6	61.3	69.875	49.1	32.0	34.9	537
EUW-24E	24	1-1/2	39.6	79.3	85.625	49.1	32.0	34.9	531
EUW-30E	30	1-1/2	48.6	97.3	101.1	49.1	32.0	34.9	532
EUW-36E	36	1-1/2	57.6	115.3		49.1	32.0	34.9	532
EUW-09F	9	2	18.0	36.0	40.5	49.1	32.0	34.9	530
EUW-12F	12	2	22.5	45.0	56.125	49.1	32.0	34.9	531
EUW-18F	18	2	31.5	63.0	71.75	49.1	32.0	34.9	538
EUW-24F	24	2	40.5	81.0	87.5	49.1	32.0	34.9	532
EUW-30F	30	2	49.5	99.0	103	49.1	32.0	34.9	533
EUW-36F	36	2	58.5	117.0		49.1	32.0	34.9	533
EUW-09G	9	3	19.1	38.3	43.063	49.1	32.0	34.9	540
EUW-12G	12	3	23.6	47.3	58.688	49.1	32.0	34.9	541
EUW-18G	18	3	32.6	65.3	74.313	49.1	32.0	34.9	548
EUW-24G	24	3	41.6	83.3	90.063	49.1	32.0	34.9	542
EUW-30G	30	3	50.6	101.3	105.6	49.1	32.0	34.9	543
EUW-36G	36	3	59.6	119.3		49.1	32.0	34.9	543



# DELTA T SYSTEMS

The True Measure of Temperature Control

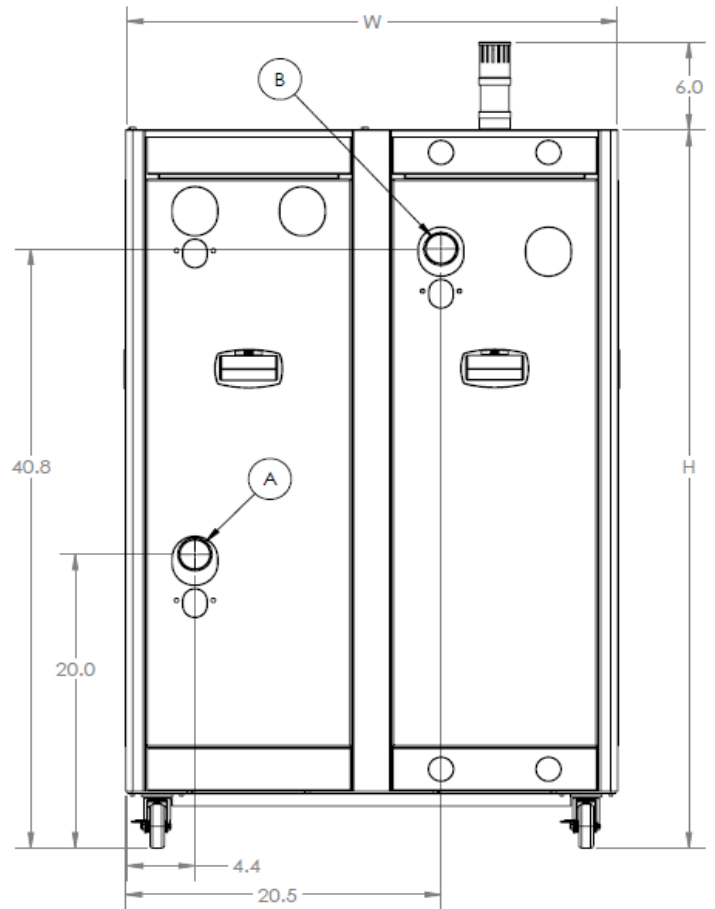
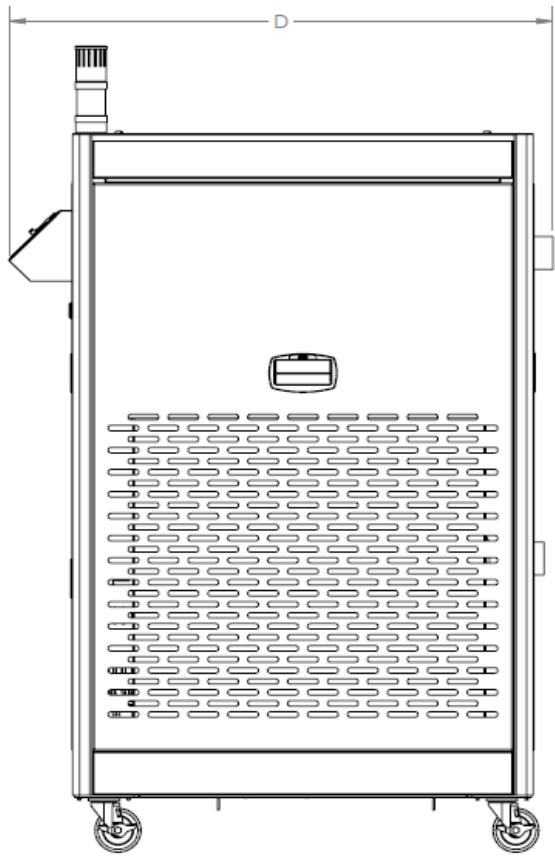

FROM PROCESS (A):	1-1/2	NPT	TO PROCESS (B):	1-1/2	NPT
-------------------	-------	-----	-----------------	-------	-----



# DELTA T SYSTEMS

The True Measure of Temperature Control

